

### Description

The 5078 is a four channel programmable-gain differential-input amplifier that provides signal conditioning for bridge type transducers. In addition to analog signal amplification each independent channel includes bridge completion, input offset bias compensation, voltage excitation with remote sense capability, local or remote shunt calibration, digital signal processing with programmable filtering and output buffering.

### Design Features

The 5078 utilizes onboard DSPs (one per channel) to configure the input circuitry and handle amplifier gain and offset compensation. High performance front end analog components are combined with digital signal processing techniques and ultra stable calibration reference sources to maintain system accuracy, bandwidth and gain tolerances. Front-panel LEDs indicate signal presence and activity level, and warn of module operational problems. All circuitry is housed in a shielded enclosure for improved reliability and noise reduction.

#### Bridge Completion

On-board bridge-completion resistors are provided for full, 1/2, or 1/4-bridge completion to accommodate a variety of sensor configurations. Bridge configuration is completely programmable, including the selection of 120 or 350 ohm completion resistors. By setting the configuration to the Full Bridge mode, the 5078 can also be used as a standard differential amplifier.

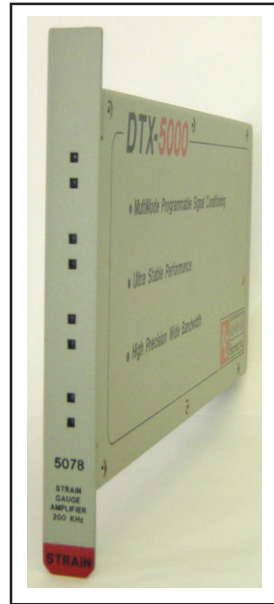

5078 Automated Strain Conditioner

#### Shunt Calibration

When CAL is activated, a pre-selected shunt cal resistor is electrically connected to the sensor to simulate a known amount of strain. Selecting Local shunt cal makes this connection inside the amplifier for simpler sensor wiring. Selecting Remote shunt cal makes this connection at the sensor (using separate shunt cal lines). Using Remote shunt cal also allows a user-supplied external shunt cal resistor to be used if desired.

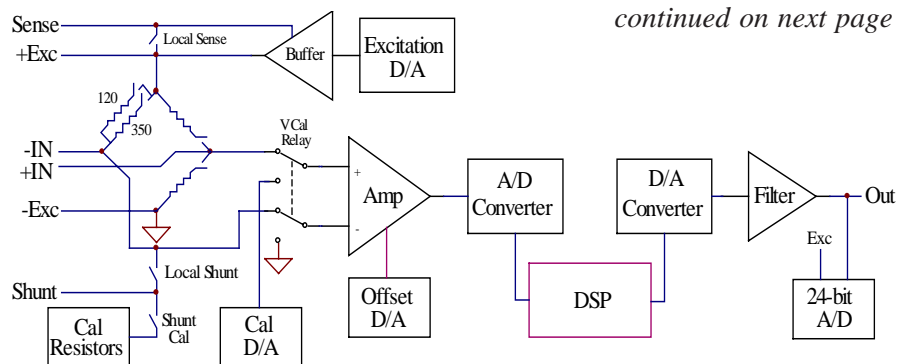

5078 Technical Diagram

### Features

- **Wideband/High Gain Inputs**  
Gain Range: 50 to 5,000  
Frequency: DC to 100kHz
- **Ultra-stable Low Noise Amps**  
Output Noise: 1 mV rms  
Stability: 50 ppm/°C
- **Sensor Voltage Excitation**
- **Bridge Completion**  
Quarter, Half, Full Bridge  
Auto Balance, Auto Gain
- **Shunt Calibration**  
Local or Remote shunt
- **LED Status Indicators**
- **Compact Rugged Enclosure**

#### DSP - Programmable Gain

The differential bridge output is fed to an instrumentation grade x10 pre-amp avoiding the use of switched resistors in the most noise and temperature-sensitive portion of the circuit. A programmable offset voltage is injected following this preamp for input offset compensation and automated bridge balancing. After offset correction, the signal is fed to a variable gain amplifier controlled by an onboard DSP prior to digitization and subsequent processing. The Digital Signal Processor uses stored offset and gain calibration factors to

*continued on next page*

*continued from previous page*  
 correct the digitized data values and generate a digitally filtered output that is ready for conversion back into an error-corrected analog output voltage.

### Output Circuit

The processed digital output is converted back to an analog voltage by a high-speed 16-bit Digital-to-Analog Converter. A four-pole low-pass filter/buffer-amp removes the digitizing steps in the reconstructed signal, along with any high-frequency noise. Temperature-stable components and ultra stable references are used to ensure that system calibration holds over a wide temperature range.

## Specifications

### General

Gain Range	50 to 5,000
Frequency Response	DC to 100 kHz
Common-Mode Rejection	80 dB @ 100 Hz
Common Mode Voltage	10v max.
Accuracy	0.05%
Linearity	0.01%
Stability	50 ppm/°C

Input Type	Differential
Input Impedance	1 Mohn
Input Noise	10 uV rms
Input Offset Balance	+/- 250 mV
Input Protection	250V max.

Output Noise	1 mV rms
Output voltage range	±10v @ 50 mA
Output impedance	50 ohms

### Bridge Completion

Configuration	Full, 1/2, 1/4
Auto Balance	Yes, Programmable
Completion resistance	120 or 350 ohms
Accuracy	0.1%, 5 ppm /°C

### DSP – AutoBalance/AutoGain

Using a programmable offset voltage allows the DSP to automatically servo the amplifier output to zero adjusting for bridge imbalance. In a like manner, the DSP can adjust the amplifier gain to a targeted value upon application of a shunt resistance or other calibration source.

### Voltage Excitation with Remote Sense Capability

The 5078 provides four independent programmable excitation voltage sources for use in powering input sensors. Each source is controlled by a 16 bit DAC with an output range from 0 to 10 Volts and 100 mA output buffering. Remote sense can also be selected to provide feedback accounting for IR losses over conductor lines between amplifier and sensor.

## System Calibration

High accuracy is obtained during the conversion process by implementing a unique end-to-end calibration scheme within the 5078 conditioner. A precision programmable voltage source is connected to the input, and two calibration voltages (0v and 80% of full-scale input) are fed in, amplified by the input stages, converted by the A/D, processed by the DSP, converted back to analog and then measured by a high-accuracy 24-bit A/D converter. The measured input and output voltages are then used to compute offset and gain correction values. During operation, their correction factors are applied to each data point in real time resulting in system accuracy better than ±0.05 of full scale.

### Low-Pass Filter

Type	Digital, programmable
Range	10 Hz to 100 kHz
Roll-off	96 dB/octave

### Signal Overload

Indicator	Front-panel LED
Trip level	0.1 to 10v

### Calibration Source

Type	Local or Remote Shunt
Internal Shunt resistors	100K, 200K, 400K
Accuracy	0.1%, 5 ppm /°C

### Excitation

Type	Programmable Voltage
Voltage range	0.1 to 10v @ 100 mA
Sense	Local or Remote
Accuracy	0.02%
Short protection	Yes

### Environmental

Operating temperature	0 to 50 °C
Storage temp	-25 to 85 °C
Humidity	0 to 90% non condensing

### Physical Characteristics

Package	Shielded, 6 sides
Dimensions	0.8" x 4.2" x 9.5"
Weight	1.3 lbs